

RUDDERS

SPEED RUDDER*

CAST MANGANESE BRONZE



Semi-wedge rudder design with the shaft and rudder cast in one piece. The rudder is unbalanced for the higher speeds. Furnished in 1" or 1-1/8" shaft size.

Blade size: 6 1/2" x 12"
Shaft length: 11-3/8"

| Description | Item No. |
|----------------------|----------|
| 1" Bronze | 8 |
| 1" Bronze Chrome | 10 |
| 1-1/8" Bronze | 9 |
| 1-1/8" Bronze Chrome | 11 |

CUSTOM WEDGE RUDDER*

CAST MANGANESE BRONZE



The ultimate in fine rudders for fast ski and speed boats. Perfect steering qualities at higher speed. This rudder is wedge shaped and has the shaft cast as an integral part of the rudder. Furnished in 1-1/8" shaft size only.

Blade size: 5 3/4" x 12"
Shaft length: 11-3/8"

| Description | Item No. |
|----------------------|----------|
| 1-1/8" Bronze | 14 |
| 1-1/8" Bronze Chrome | 15 |

COMPETITION STEEL RUDDER*

4130 ALLOY STEEL



Our highest quality 4130 alloy steel competition rudder. Beautifully chrome plated. Recommended for boats operating in a higher speed range. Furnished in 1" and 1-1/8" shaft size.

Blade size: 5 1/2" x 12"
Shaft length: 12"

| Description | Item No. |
|-------------|----------|
| 1" | 12 |
| 1-1/8" | 13 |

CUSTOM CRUISER RUDDER*

CAST MANGANESE BRONZE



An ideal rudder for cruisers up to 25 feet. Offers excellent steering control and responsive handling. Furnished in 1-1/8" shaft size only.

Blade size: 7 1/2" x 12 1/2"
Shaft length: 14"

| Description | Item No. |
|-------------|----------|
| 1-1/8" | 16 |

***RUDDER NOT KEYED. IF YOU WANT US TO KEY RUDDER, MEASURE UP FROM BLADE, SPECIFY WHERE YOU WANT KEYWAY AND LENGTH OF KEYWAY.**

RUDDERS

UNIVERSAL RUDDER*

CAST MANGANESE BRONZE

A balanced rudder with integral cast shaft. Ideal for speed boats or small cruisers. Furnished in 1" or 1-1/8" shaft size.

Blade size: 9 1/4" x 9"
Shaft length: 10"



SPEED RUDDER*

STAINLESS STEEL

This is the same style of rudder as our bronze speed rudder, except that it is made of stainless steel and is polished to a high luster finish. Available in 1" and 1-1/8" shaft size.

Blade size: 6 1/2" x 12"
Shaft length: 11-3/8"



Description

1"
1-1/8"

Item No.

19
20

Description

1"
1-1/8"

Item No.

1160
1161

CRUISER RUDDER*

CAST MANGANESE BRONZE

A perfectly balanced rudder for cruisers and larger speed boats. This rudder has an integral cast shaft. Furnished in 1-1/8" shaft size only.

Blade size: 10" x 14"
Shaft length: 14"



CUSTOM WEDGE RUDDER*

STAINLESS STEEL

This is the same style of rudder as our bronze wedge rudder, except that it is made of stainless steel and is polished to a high luster finish. Available in 1" and 1-1/8" shaft size.

Blade size: 5 3/4" x 12"
Shaft length: 11-3/8"



Description

1-1/8"

Item No.

21

Description

1"
1-1/8"

Item No.

1180
1181

***RUDDER NOT KEYED. IF YOU WANT US TO KEY RUDDER, MEASURE UP FROM BLADE, SPECIFY WHERE YOU WANT KEYWAY AND LENGTH OF KEYWAY.**

RUDDERS

CUSTOM WEDGE CRUISER RUDDER*

CAST MANGANESE BRONZE



Designed for the faster small cruisers. Furnished in 1-1/8" shaft size only.

Blade size: 6 1/2" x 12"
Shaft length: 12"

Description
1-1/8"

Item No.
1267

TOURNAMENT SKI BOAT RUDDER

CAST MANGANESE BRONZE



Intended for tournament ski boat applications. Designed to maximize steering control and tracking stability. Furnished in 1-1/8" shaft size only.

Blade size: 8 1/2" x 12 1/2"

Description

6-1/8" Shaft Length

10" Shaft Length

***RUDDER IS KEYED ON LEFT SIDE 12° OFF OF 90°.**

Item No.

1287*

1287L

COMPETITION STEEL SPEED RUDDER*



High quality 4130 Chrome Moly, heat treated steel. Chrome plated competition rudder. Recommended for boats operating at elevated speeds. Furnished in 1" or 1-1/8" shaft size.

Blade size: 6 1/2" x 12"
Shaft length: 12"

Description

1"

1-1/8"

Item No.

1268

1269

COMPETITION STEEL SPADE RUDDER*



High quality 4130 Chrome Moly, heat treated steel. Chrome plated competition rudder. Designed for light cruisers with turbo systems. Furnished in 1" or 1-1/8" shaft size.

Blade size: 7" x 12"
Shaft length: 12 1/2"

Description

1"

1-1/8"

Item No.

1290

1291

***RUDDER NOT KEYED. IF YOU WANT US TO KEY RUDDER, MEASURE UP FROM BLADE, SPECIFY WHERE YOU WANT KEYWAY AND LENGTH OF KEYWAY.**

COUPLERS • COLLARS • PROP NUTS • KEYS • PINS

SPLIT SLEEVE COUPLER - STEEL



This type of coupler is used on V-drives with 1" shafts.

| Length | O.D. | I.D. | Item No. |
|---------------|------|------|----------|
| 3 1/2" Cad | 2" | 1" | 868 |
| 3 1/2" Chrome | 2" | 1" | 869 |

SPLIT SAFETY COLLARS - STEEL



| Diameter | Item No. |
|---------------|----------|
| 1" Cad | 461 |
| 1" Chrome | 463 |
| 1-1/8" Cad | 462 |
| 1-1/8" Chrome | 464 |

SAFETY COLLARS STAINLESS STEEL



These safety collars are used on the rudder shaft and prop shaft.

| Diameter | Item No. |
|----------|----------|
| 3/4" | 402 |
| 7/8" | 403 |
| 1" | 400 |
| 1-1/8" | 401 |

STRUT COLLARS STAINLESS STEEL



These strut collars are used on propeller shaft ahead of the strut.

| Diameter | Item No. |
|----------|----------|
| 1" | 4001 |
| 1-1/8" | 4002 |

PROP NUT KIT STAINLESS STEEL



Item No.
723

COTTER PIN STAINLESS STEEL



Item No.
722

PROPELLER NUTS BRASS AND S.S.



Thread Size
3/4 - 10 (Brass)
Half Nut (S.S.)

Item No.
725
726

LOCKING PROPELLER NUTS STAINLESS STEEL



Thread Size
3/4 - 10
3/4 - 16

Item No.
727
727-F

PROPELLER KEYS STAINLESS STEEL



Size
1/4 x 1/4

Item No.
724

RUDDER STUFFING BOXES • PLATES

DOUBLE SEAL TYPE STUFFING BOX

CAST BRASS

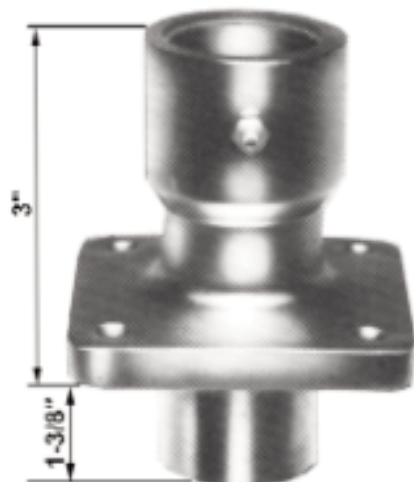

This competition rudder stuffing box uses a double seal on top and an "O" ring on the bottom, giving greater rudder shaft stability and assuring a positive leak-proof unit.

Base: 3-5/16" x 3-5/16"

Holes: center to center 2-3/8"

O.D. - 1- 5/8"

| Description | Item No. |
|---------------------------------------|----------|
| 1" Brass | 135 |
| 1" Brass Chrome | 137 |
| 1-1/8" Brass | 136 |
| 1-1/8" Brass Chrome | 138 |
| Extra Seal - 1" | 233 |
| Extra Seal - 1-1/8" | 238 |
| Extra "O" ring (specify 1" or 1-1/8") | 139 |

SINGLE SEAL TYPE STUFFING BOX

CAST BRASS

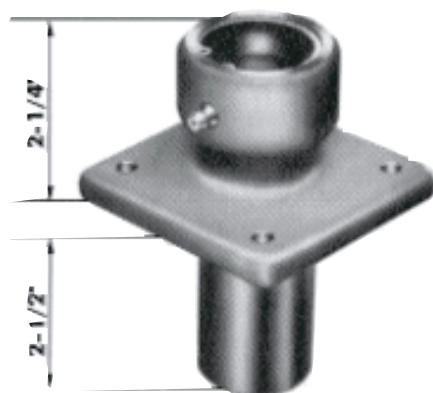

This rudder stuffing box uses a neoprene seal. Furnished in 1" or 1-1/8" rudder shaft size.

Base: 3-1/4" x 3-1/4"

Holes: center to center 2-5/16"

O.D. - 1-1/2"

| Description | Item No. |
|---------------------|----------|
| 1" Brass | 112 |
| 1" Brass Chrome | 114 |
| 1-1/8" Brass | 113 |
| 1-1/8" Brass Chrome | 115 |

RUDDER STUFFING BOX PLATE

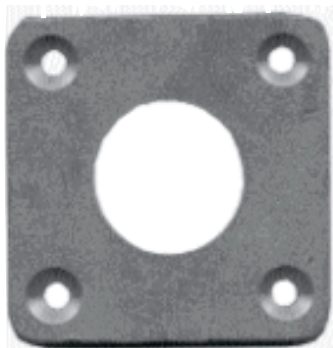

| Description | Item No. |
|----------------------------------|----------|
| 3 1/4" X 3 1/4" Brass | 107 |
| 3 1/4" X 3 1/4" Brass Chrome | 109 |
| Holes: center to center 2-3/8" | |
| 4" x 4" Brass | 108 |
| 4" x 4" Brass Chrome | 110 |
| Holes: center to center 2-13/16" | |

RUDDER STUFFING BOXES

HEAVY DUTY STUFFING BOXES

PACKING TYPE - CAST BRASS

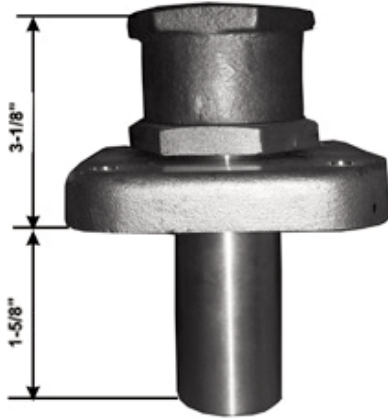

Designed for rudders using a 1-1/8" shaft.

Base: 4" x 4"

Holes: center to center 2-3/4"

O.D. - 1-1/2"

Description
Heavy Duty

Item No.
101**

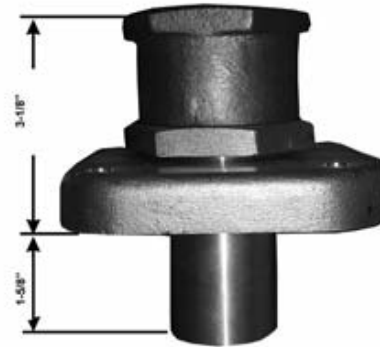

Designed for Tournament ski boat applications. This stuffing box is used with our Tournament ski boat rudder for 1-1/8" shaft.

Base: 4" x 4"

Holes: center to center 2-3/4"

O.D. - 1-1/2"

Description
Tournament

Item No.
1289**

MEDIUM DUTY STUFFING BOX

PACKING TYPE - CAST BRASS

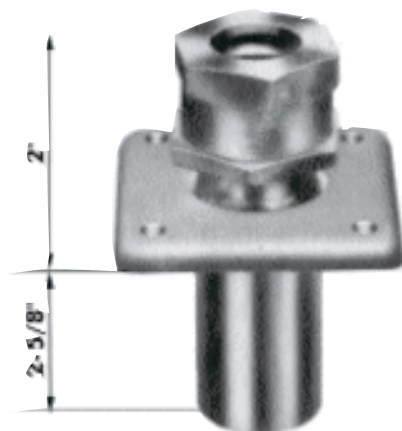

Base: 3 1/4" x 3-1/4"

Holes: center to center 2-5/16"

O.D. - 1-1/2"

Description

1" Brass

1" Brass Chrome

1-1/8" Brass

1-1/8" Brass Chrome

Item No.

102***

104***

103*

105*

Description

Extra Packing:

Item No.

106

*3/16" **5/16" ***1/4" - Please size specify when ordering

QUADRANT TILLERS • BRACKETS

CUSTOM RUDDER QUADRANT



CAST BRONZE OR ALUMINUM

This heavy duty quadrant has a clamp type boss for simple installation. The bolt locks the quadrant to the shaft. Quadrant has a 5" radius and a 1/4" keyway for added safety.

| Description | Item No. |
|--------------------------|----------|
| 1" Aluminum | 36 |
| 1" Aluminum-Polished | 38 |
| 1" Bronze | 40 |
| 1" Bronze Chrome | 42 |
| 1-1/8" Aluminum | 37 |
| 1-1/8" Aluminum-Polished | 39 |
| 1-1/8" Bronze | 41 |
| 1-1/8" Bronze Chrome | 43 |

CUSTOM TILLER



CAST MANGANESE BRONZE

This tiller is furnished with a 1" or 1-1/8" hole. Easy installation with clamp type single nut and bolt design. Bolt locks tiller to shaft. Tiller has a 1/4" keyway for added safety. Length: 7".

| Description | Item No. |
|----------------------|----------|
| 1" Bronze | 28 |
| 1" Bronze Chrome | 30 |
| 1-1/8" Bronze | 29 |
| 1-1/8" Bronze Chrome | 31 |



RUDDER POST BRACKET

CAST ALUMINUM

Hi-tensile aluminum casting for supporting the rudder shaft. The quadrant can ride below or above the bracket. The bracket fastens between or on top of the engine stringers. Furnished with 1" or 1-1/8" brass bushing and aluminum angle. Length: 3" x 28".

| Description | Item No. |
|--------------------------|----------|
| 1" Aluminum | 32 |
| 1" Aluminum-Polished | 34 |
| 1-1/8" Aluminum | 33 |
| 1-1/8" Aluminum-Polished | 35 |



COMPETITION RUDDER POST BRACKET

CAST ALUMINUM

This rudder post bracket is competition engineered. Bracket fastens between or on top of engine stringers. Furnished with 1" or 1-1/8" brass bushing and aluminum angle. Length: 2 3/4" x 26".

| Description | Item No. |
|--------------------------|----------|
| 1" Aluminum | 22 |
| 1" Aluminum-Polished | 24 |
| 1-1/8" Aluminum | 23 |
| 1-1/8" Aluminum-Polished | 25 |

TRANSOM BRACKETS



RUDDER TRANSOM BRACKET CAST ALUMINUM HI-TENSILE

Designed for slanted transoms. Used when converting outboard hulls to inboard. Available in 1" or 1-1/8".

Height: 6"

Width: 8½"

Depth: 8"

Description

1"

1-1/8"

Item No.

1

2



RUDDER TRANSOM BRACKET CAST ALUMINUM HI-TENSILE

An exceptionally strong ribbed bracket. Designed for straight or verticle transoms. Available in 1" or 1-1/8".

Height: 6½"

Width: 7"

Depth: 7"

Description

1"

1 1/8"

Item No.

3

4